

# Basics of Emissions

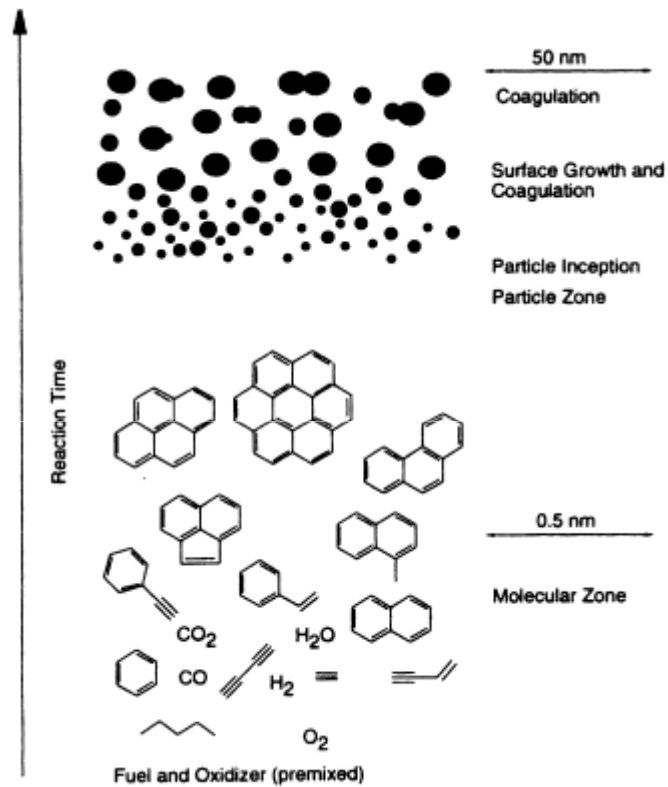

S. Sreedhara

# Outline

Emission regulations

Ill effects of Emissions

Sources of Emissions

Technologies to reduce emissions

# Why to bother about emissions

Emission regulations

Ill effects of emissions

# Locomotive Emissions Regulations

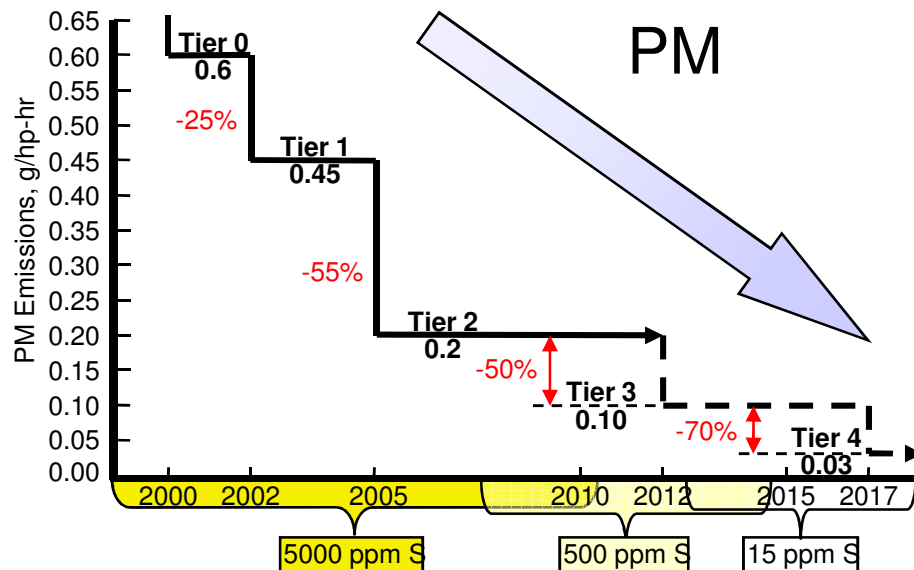
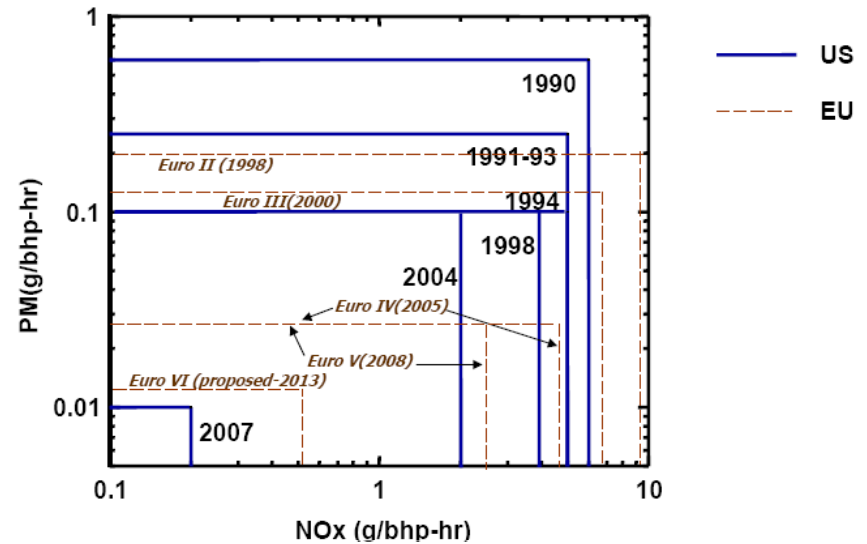
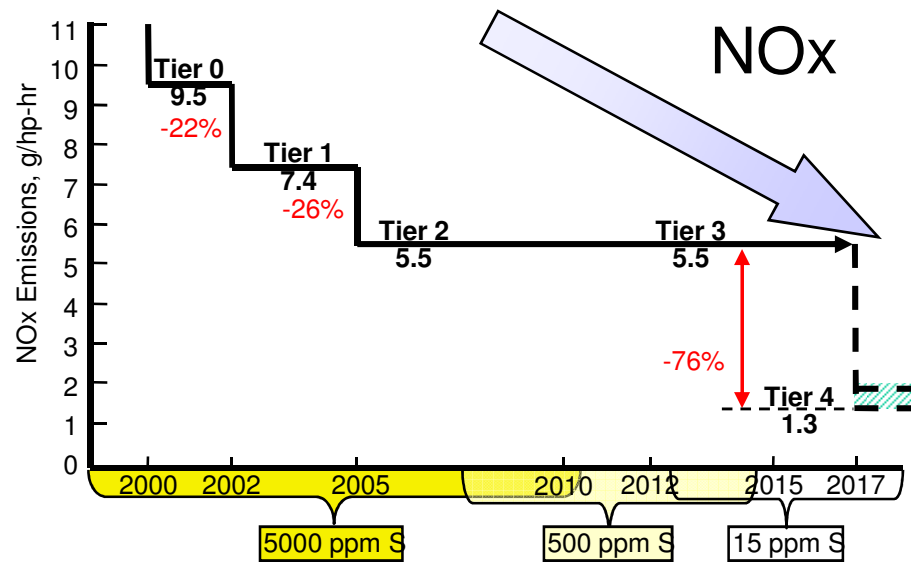

Tier 1, 2, 3, 4 etc  
Euro 1, 2, 3, 4 etc  
Bharath norms

# Technologies to meet Emissions Regulations

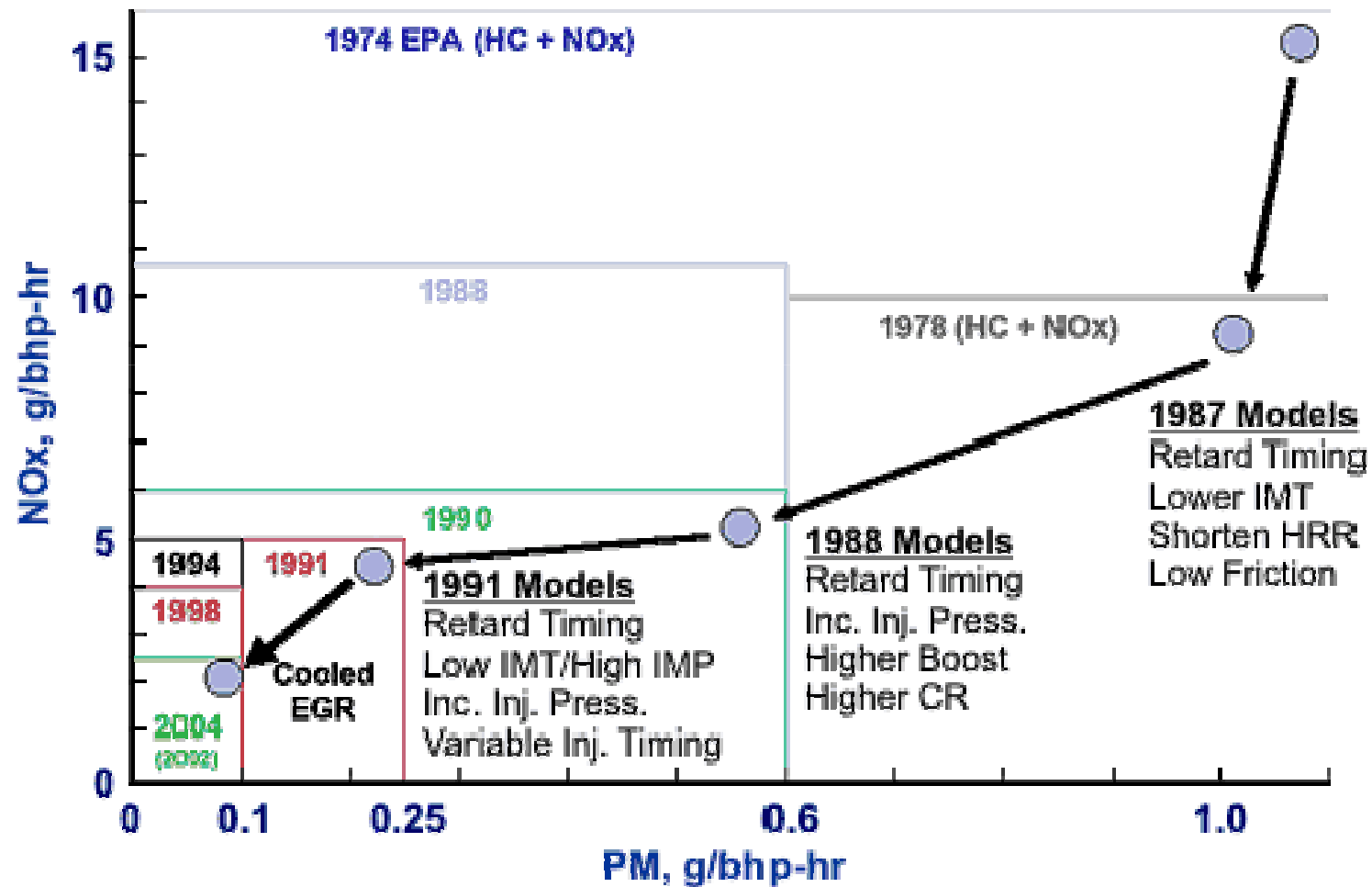

# Ill effects of various emissions

**Carbon di-oxide (CO<sub>2</sub>):** It is a major absorber of infrared radiation emitted towards the space from the earth surface. Thus, it has crucial role in planetary temperature structure.

**Carbon monoxide (CO):** High concentration of CO in blood makes it difficult for heart to pump blood through arteries.

**Hydrocarbons (HC):** Unburnt hydrocarbon affects central nervous system.

## Ill effects of various emissions contd...

**Oxides of nitrogen (NO<sub>x</sub>):** Causes dilatation of air spaces in lungs. NO<sub>2</sub> causes damages to bronchioles and alveolar ducts. NO<sub>2</sub> is also suspected to impair the defense mechanism of respiratory system. Infants and children are more susceptible.

**Particulate matter:** Diesel emits suspended particulate matter (SPM) which contains soot. Soot is responsible for reduction of atmospheric visibility and carry organic compound to lungs.

**Lead (Pb):** Around 75% of the ingested lead is deposited in bones and tissues causing irreversible brain and kidney damage. Growing nervous system of young children are particularly vulnerable.

# Sources of emissions

## Carbon Monoxide (CO):

- Mainly due to incomplete combustion
- Intermediate compound; oxidizes to CO<sub>2</sub> as combustion proceeds
- Lack of oxidants and low gas temp
- Short residence time

## Unburnt Hydro Carbons (UBHC):

- Too lean to burn
- Spray core ...too rich too cold to burn
- Quenched fuel on the walls
- Spray tail with larger droplets
- Misfire

# Thermal NO<sub>x</sub>

Thermal NO is formed from oxidation of atmospheric nitrogen at relatively high temperatures in fuel-lean environments, and has a strong temperature-dependence (> 1600-1800 K).

This process is described by the widely accepted Zeldovich two-step mechanism

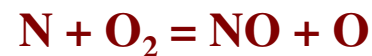

Additional elementary reaction is often added to the thermal NO mechanism



Referred to as the modified or extended Zeldovich mechanism.

Applicable in some cases when NO formation from the Zeldovich mechanism is under-estimated

# Prompt NO<sub>x</sub>

Hydrogen Cyanide (HCN) is formed by the reaction of atmospheric nitrogen with hydrocarbon radicals in fuel-rich regions of flames.

HCN subsequently oxidizes to form NO. The main reactions proposed to describe this process are:

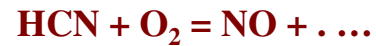

Prompt NO formation occurs in **fuel-rich** regions where hydrocarbon radicals increase the formation of HCN.

Prompt NO formation is less prevalent in fuel-lean hydrocarbon flames.

Prompt NO reactions are neglected in many NO models due to the increased complexity.

# Fuel NO<sub>x</sub>

Nitrogen contained in the fuel is partially converted to fuel NO, which may sometimes be up to 75–95% of total NO emission.

For eg. the composition of Vacuum Residue

C:85.30%, H: 10.34%, O: 0.13%, N: 0.45% and S: 3.78%.

The fuel nitrogen evolves primarily as HCN and to a less extent as NH<sub>3</sub>. Later these will be converted into NO

## Reburning

It is a process used to reduce NO emissions by the addition of a hydrocarbon-containing fuel into the downstream combustion zone. The additional fuel creates a fuel-rich region, which provides CH<sub>i</sub> radicals that react with NO<sub>x</sub> to form HCN, which can then be reduced to N<sub>2</sub>. (**Post Injection**)

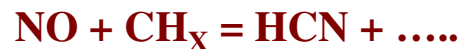

# Schematic diagram for NO<sub>x</sub> formation

1.  $N_2 + O \rightleftharpoons NO + N$
2.  $O_2 + N \rightleftharpoons NO + O$
3.  $N + OH \rightleftharpoons NO + H$

**Thermal Nox; Major portion**

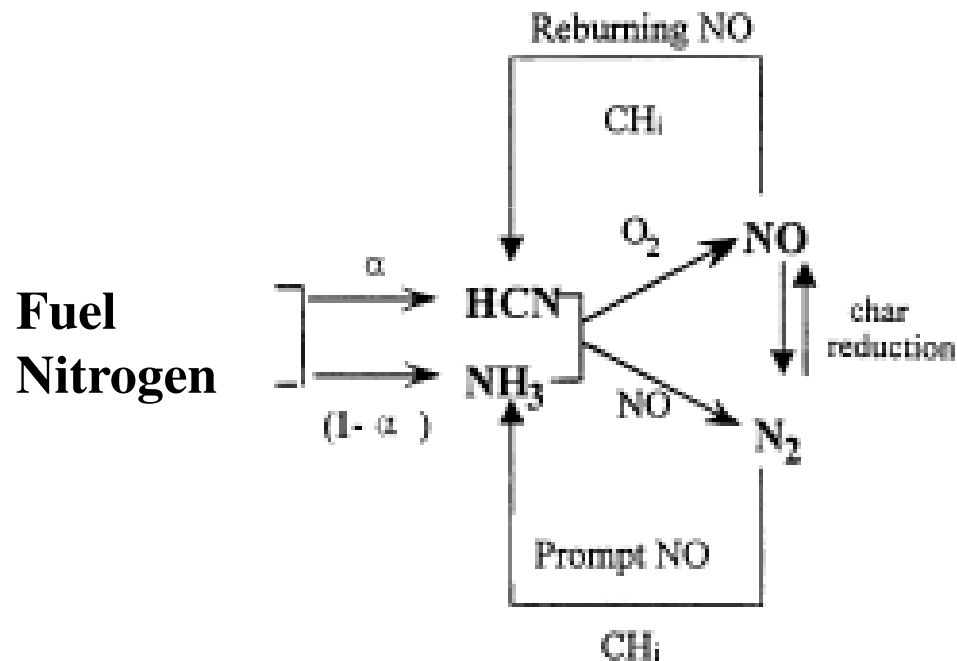

More severe in CI engine than in SI engine due to higher CR

# Particulate matter

## Sources:

- Smoke from excessive richness; over fuelling, Poor combustion
- White smoke: Cold start, Misfire
- Late injection; insufficient oxidants (less residence time)
- Fuel quality: Sulphur content etc

# Schematic diagram for SOOT formation

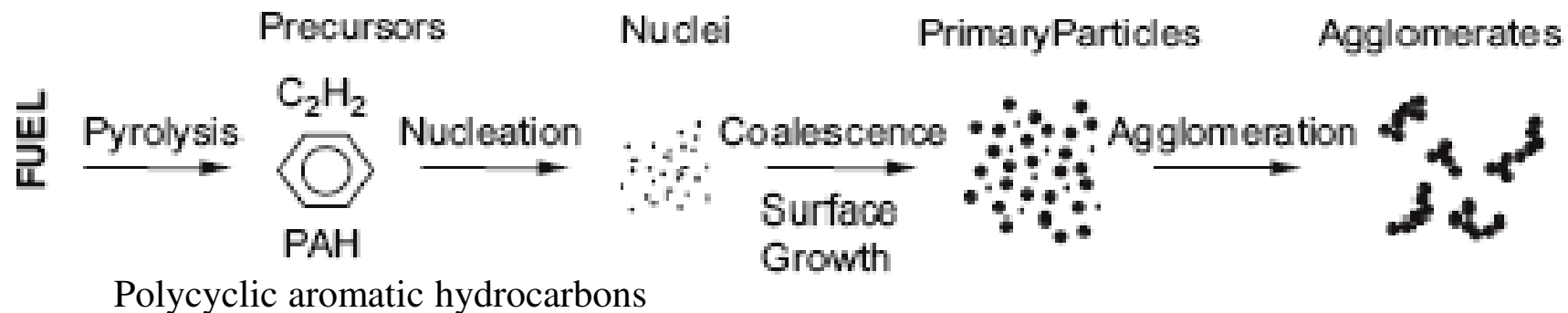

## Fuel pyrolysis

- The process of organic compounds altering their molecular structure in the presence of high temperature without significant oxidation.
- Pyrolysis reactions are generally endothermic

## Nucleation

- Nucleation or soot particle inception is the formation of particles from gas-phase reactants.
- Smallest identifiable solid particles in luminous flames have diameters in the range 1.5–2 nm, generally referred to as nuclei.

## Surface growth

- Surface growth is the process of adding mass to the surface of a nucleated soot particle.
- There is no clear distinction between the end of nucleation and the beginning of surface growth
- During surface growth soot mass increases, while the number of particles remains constant.

# Coalescence and agglomeration

- Coalescence and agglomeration are both processes by which particles combine.
- Coalescence occurs when particles collide and coalesce, thereby decreasing the number of particles and holding the combined mass of the two soot particles constant.
- Agglomeration occurs when individual or primary particles stick together to form large groups of primary particles. The primary particles maintain their shape.

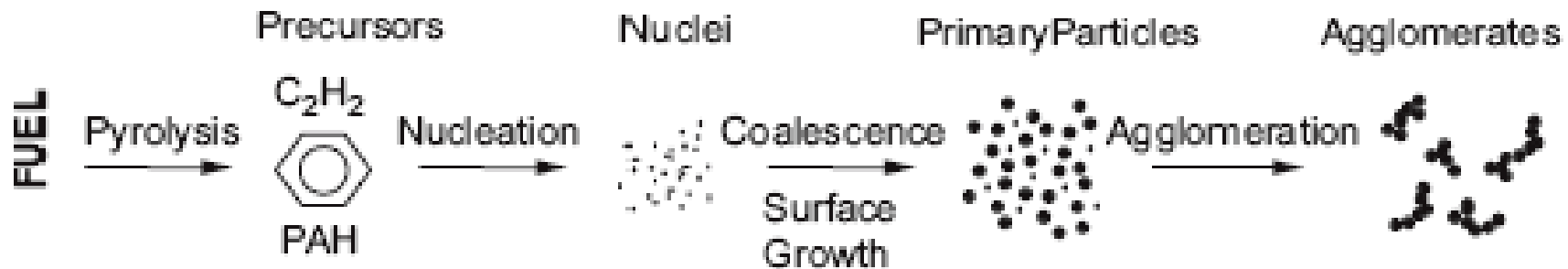

# Methods to improve efficiency and reduce emission

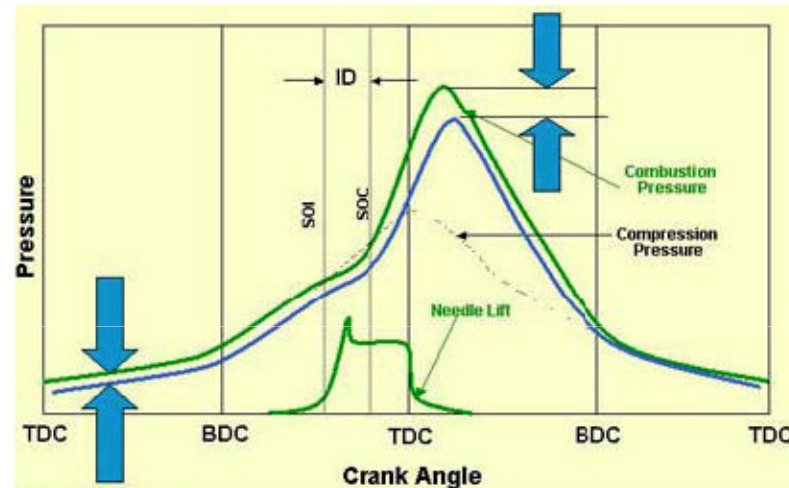

**S. Sreedhara**

## ***NOx Reduction in Diesel Engine***

### **In-cylinder reduction**

- **Combustion system optimization**
- **Injection system optimization**
- **Turbo charging**
- **EGR**

### **After Treatment**

- **Selective catalytic reduction**
- **NOx storage reduction catalyst**

### ***Technologies to reduce SOOT***

- **Improvement of diffusion combustion**
- **Optimization of injection rate, shape and timing**
- **Optimization of combustion chamber for better air utilization**
- **Diesel particulate filter**

# Methods to improve efficiency and reduce emission

EGR : Reduce the temperature level; CO<sub>2</sub> recirculation

After treatment : SCR, DPF

Pure Oxygen Combustion

Miller Cycle: Effective compression ratio and Inlet conditions

Turbocharged: More mass of fuel

HCCI: Reduced emission (with EGR)

Water Injection

Variable compression ratio

Dual fuel: Natural gas + Diesel

# Exhaust or CO<sub>2</sub> recirculation

Most commonly used method in petrol and diesel engines.

EGR works by re-circulating a portion of an engine's exhaust gas back to the engine cylinders.

**Types of EGR** : Internal and External  
: Cooled and un-cooled

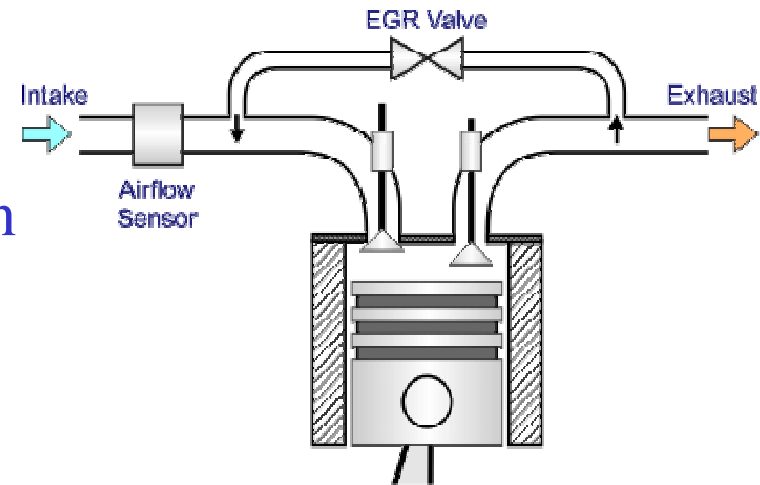

Inert exhaust displaces the amount of combustible matter in the cylinder.  
0-50% EGR is used depending on required emission reduction

$N_2 = 0.755$   
 $O_2 = 0.195$   
 $CO_2 = 0.035$   
 $H_2O = 0.015$   
Others = negligible

} AIR+EGR

$N_2 = 0.77$   
 $O_2 = 0.23$

} AIR

# Exhaust or CO<sub>2</sub> recirculation

EGR dilutes the mixture and reduces the temperature level inside the cylinder, which in turn reduces NO<sub>x</sub>.

Addition of exhaust gas increases the specific heat capacity of the mixture, which lowers the adiabatic flame temperature.

$$\text{Heat added} = mc_p (T_f - T_{in})$$

↑                      ↓

In general reduces efficiency  
and increases soot

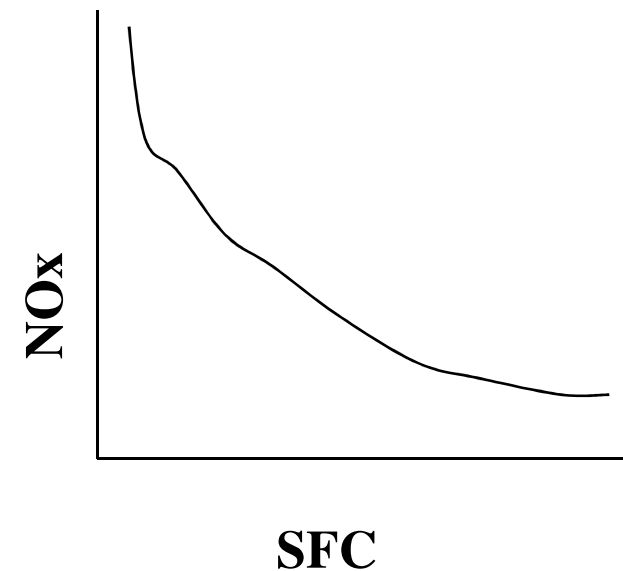

# Methods of EGR

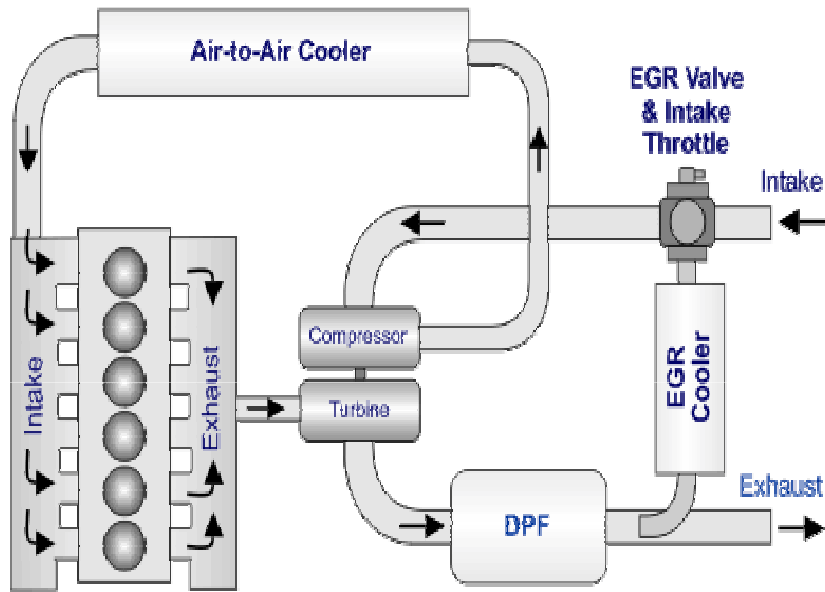

**Low pressure EGR loop**

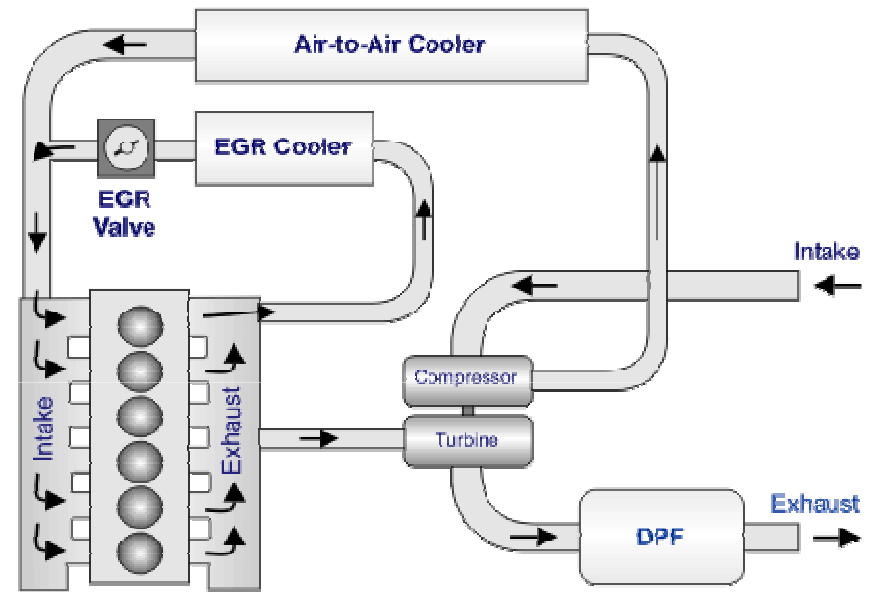

**High pressure EGR loop**

# NOx reduction

- Retardation of Injection Timing
- Intake charge cooling

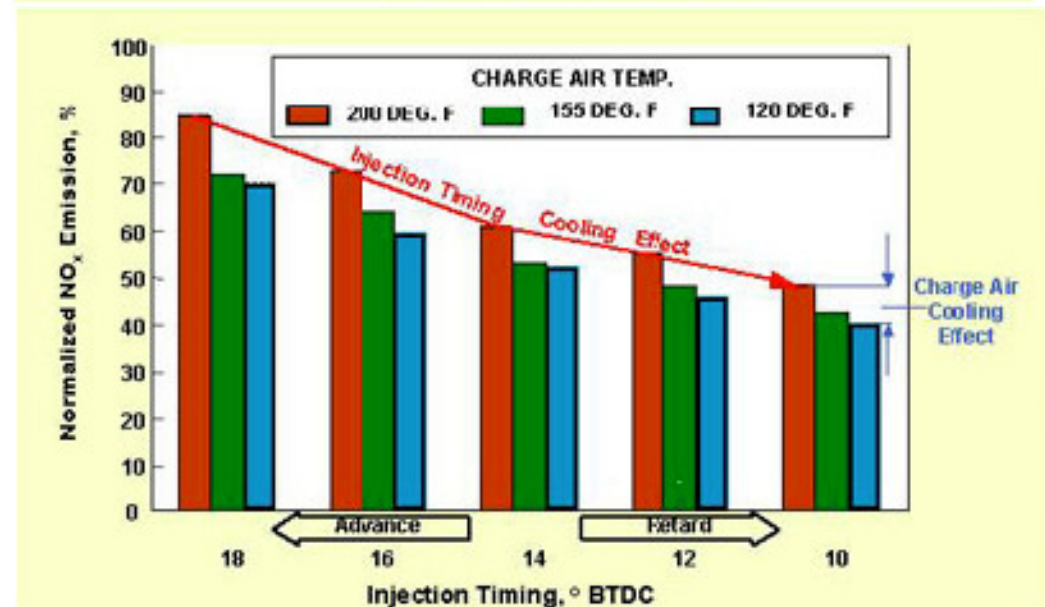
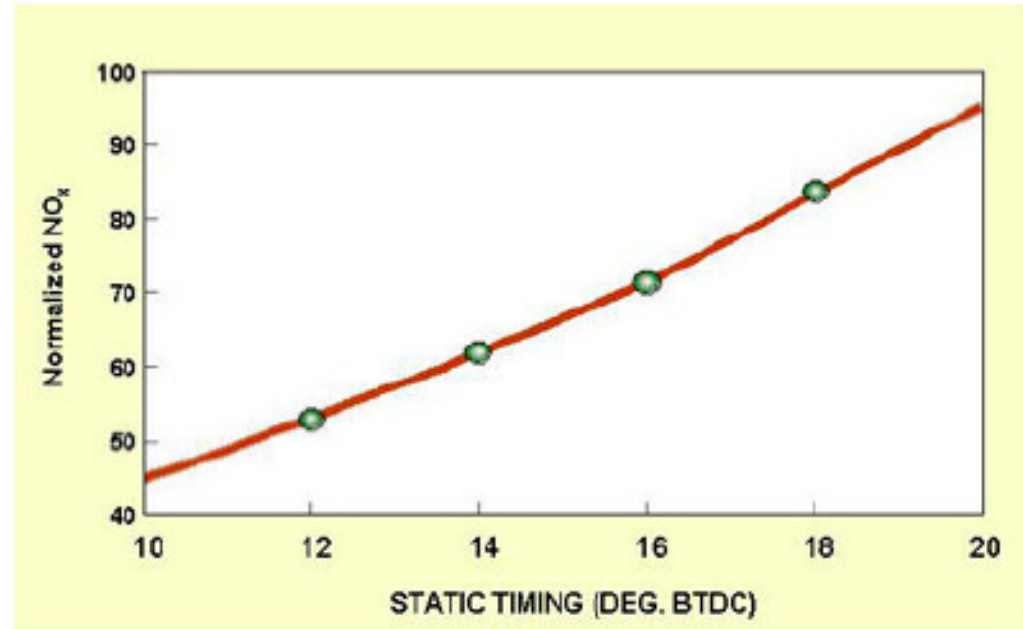
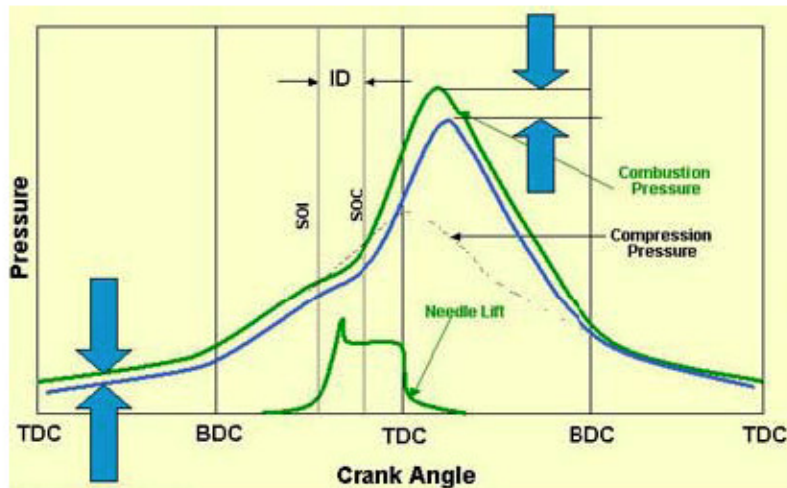

# NOx reduction

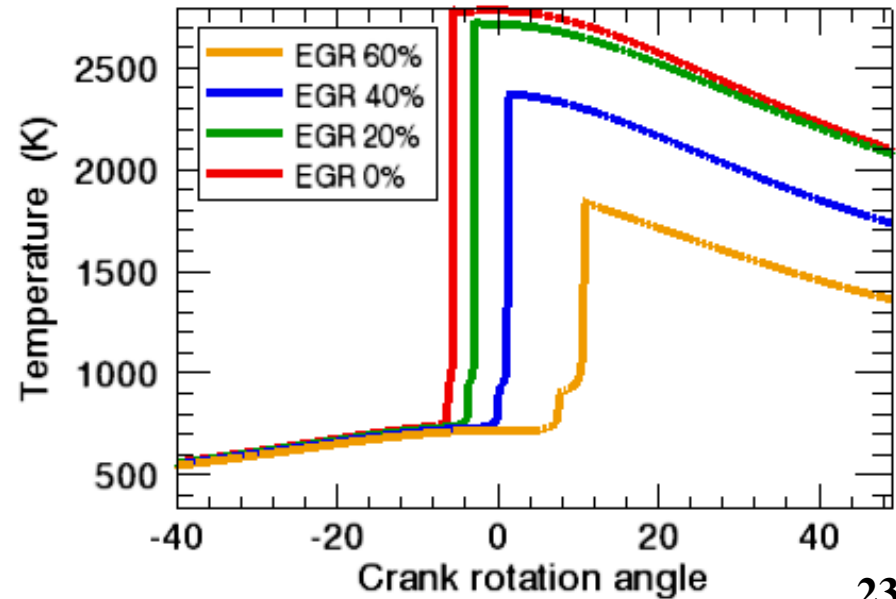
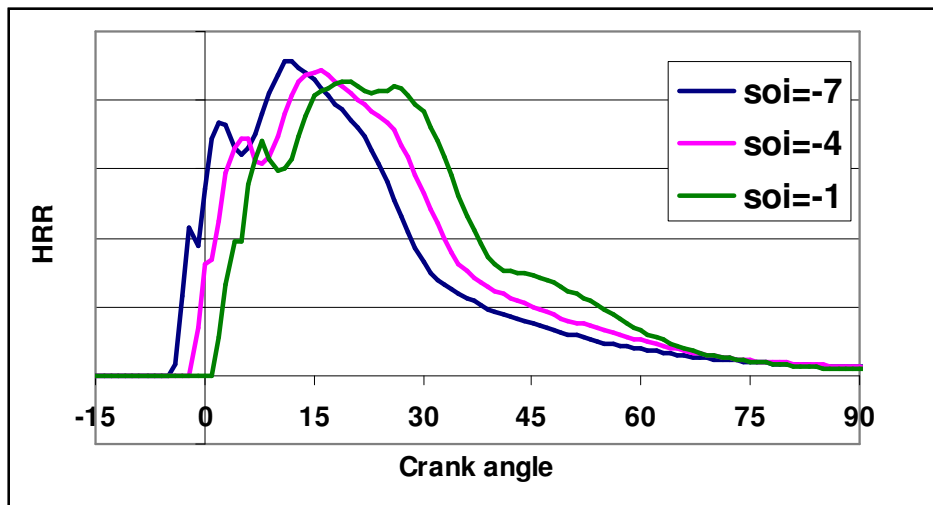
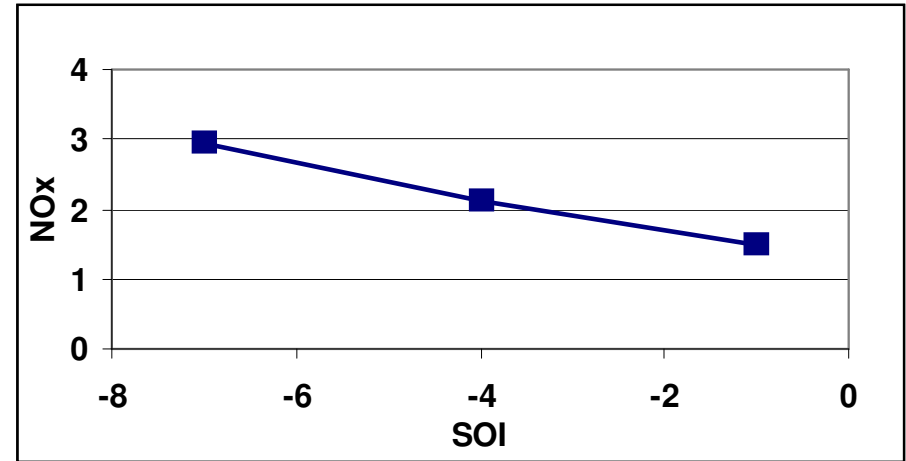
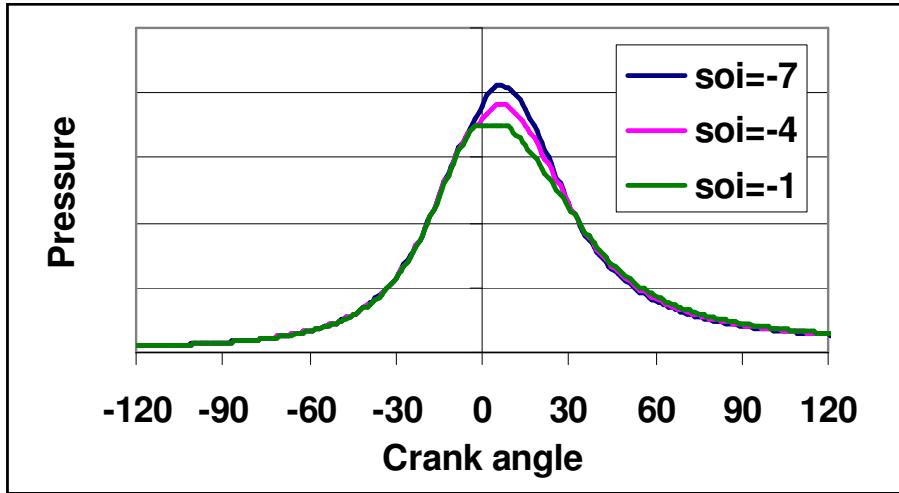

# After treatment

- Emissions are converted into non harmful species using catalytic reactions; Selective Catalytic Reactor (SCR)
- Urea based catalyst
- Diesel based catalyst

## Schematic layout of SCR catalyst

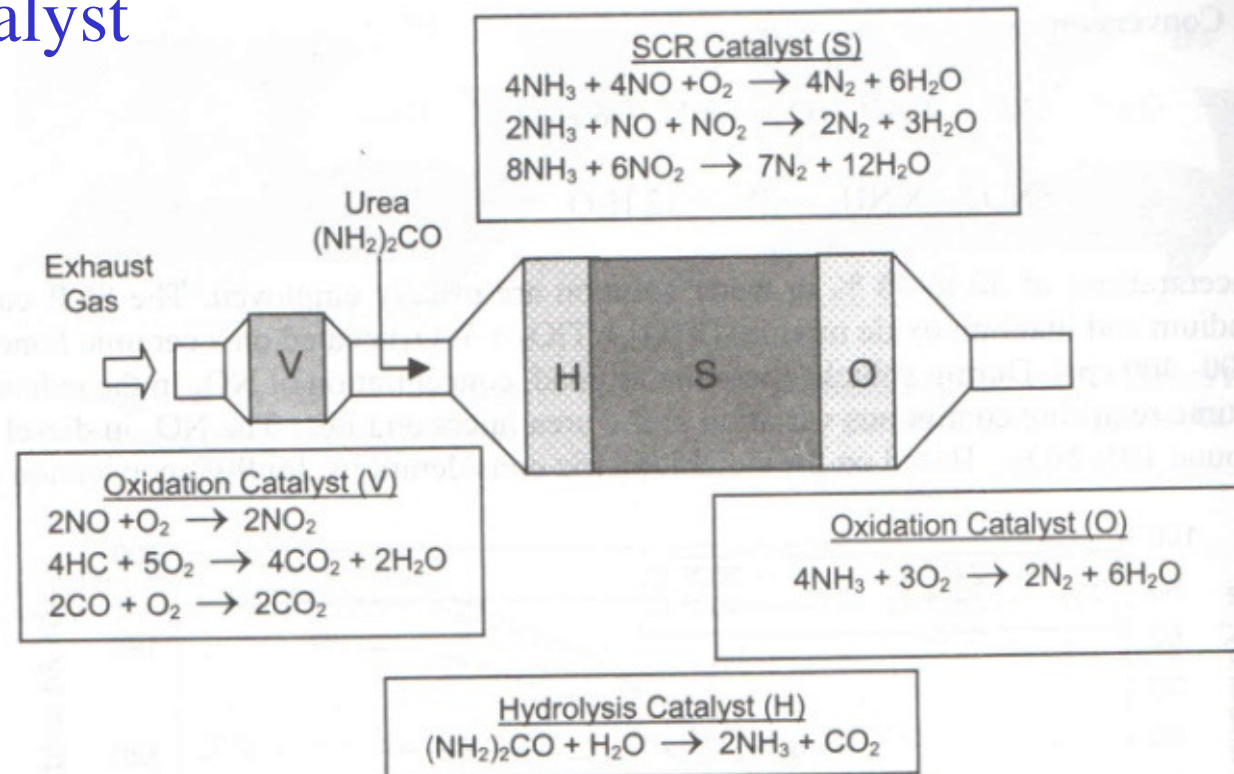

# NOx Storage Catalyst (NOx traps)

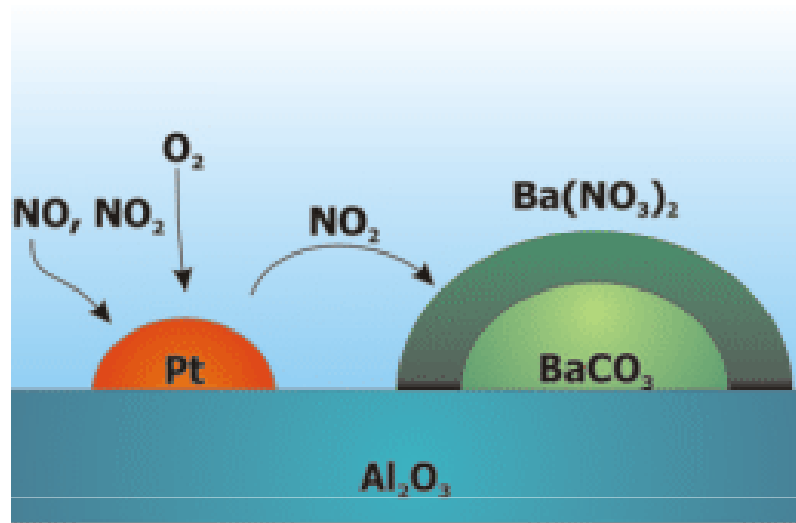

**Lean condition**

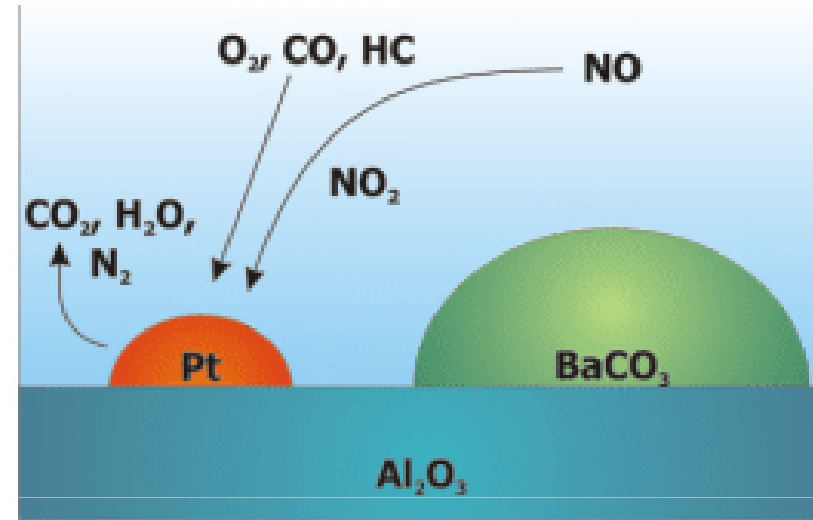
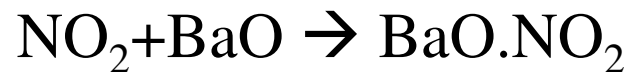
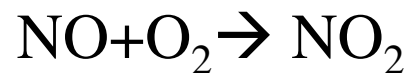

**Rich condition**

**Over Platinum catalyst**

**Barium nitrate**

**Barium nitrate**

# After treatment; DPF

- Soot lip in the combustion chamber for better utilization of air
- Soot particles are filtered using Diesel Particulate Filter (DPF)
- Additional space requirement
- Cost

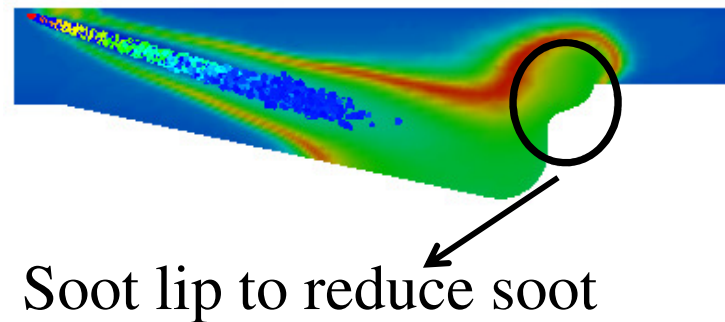

# Pure Oxygen Combustion

- Use pure oxygen instead of air
- Separate  $O_2$  and  $H_2$  from  $H_2O$ ; Use  $O_2$  for combustion and  $H_2$  may be used as fuel at some other place.
- Very high combustion temperature
- Small traces of Nitrogen can cause very high  $NO_x$

# Miller Cycle; Turbocharging

- Miller cycle: Change valve timing for inlet valve
- Theoretical closure of inlet valve is at BDC (-180 CA)
- Inlet valve may close from -220 CA to -140 CA
- Inlet pressure and Temperature may be varied
- Effective compression ratio varies
- IVC= -140 CA → effective CR reduces
- Turbocharging can increase the mass of the fuel and hence power may be increased

# Improved Combustion system

- Fuel injection: higher injection pressure; multiple injection per cycle, injection rate shaping
- Combustion chamber geometry and air motion optimization, swirl
- Reduced oil consumption to reduce HC contribution to particulates
- Cleaner fuels

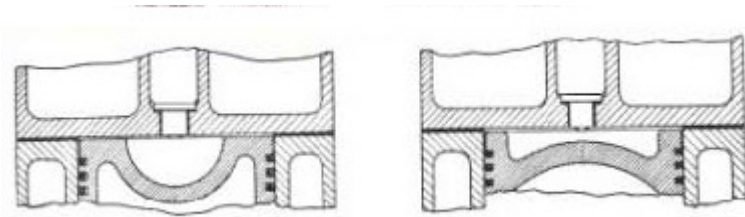

How the bowl shape in combination with the spray angle influences the in cylinder aerodynamic

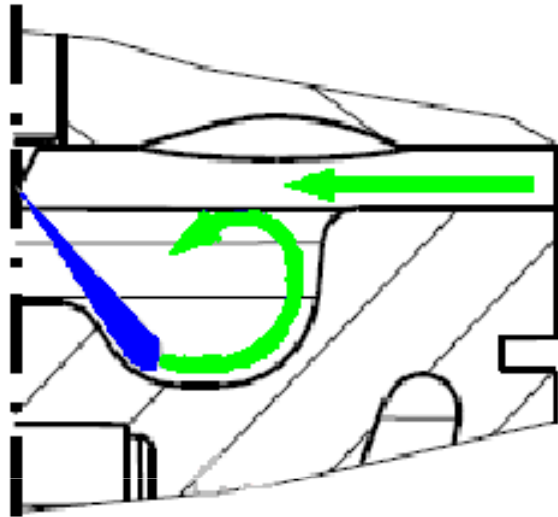

Wall guided system

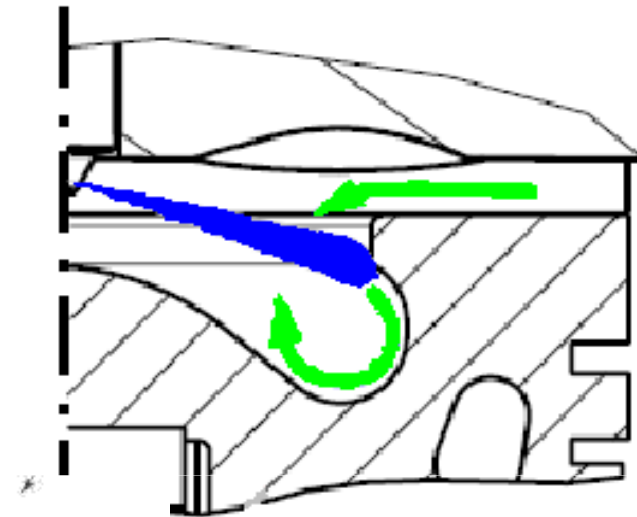

Re-entrant

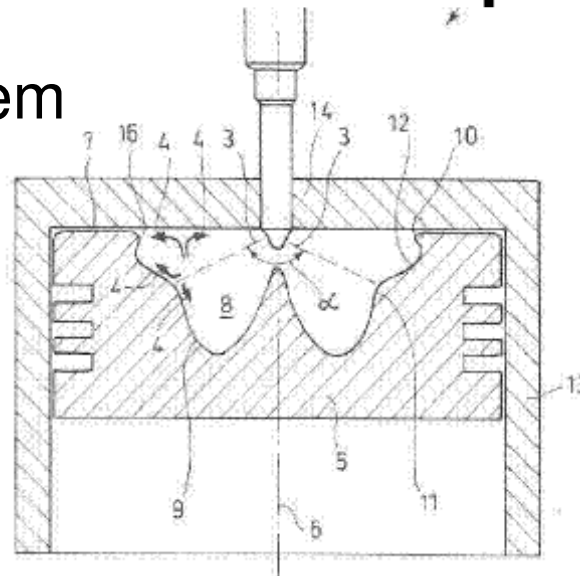

Bowl with lip or "2 step" combustion

# HCCI or PDC

- Homogeneous mixture  $\rightarrow$  Low soot
- If EGR is used  $\text{NO}_x$  may be reduced
- High peak pressure
- Preparing homogeneous mixture is difficult
- Combustion control is difficult
- Additives

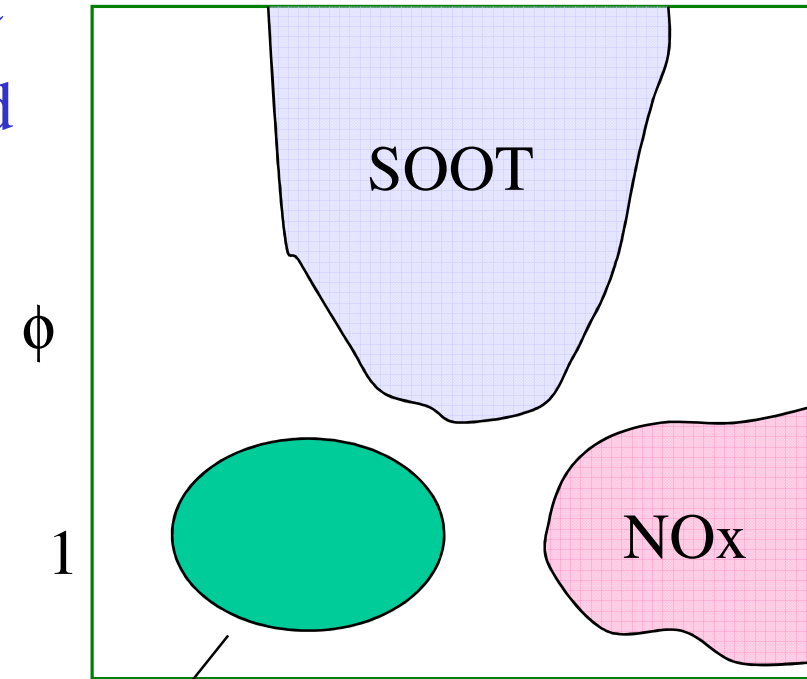
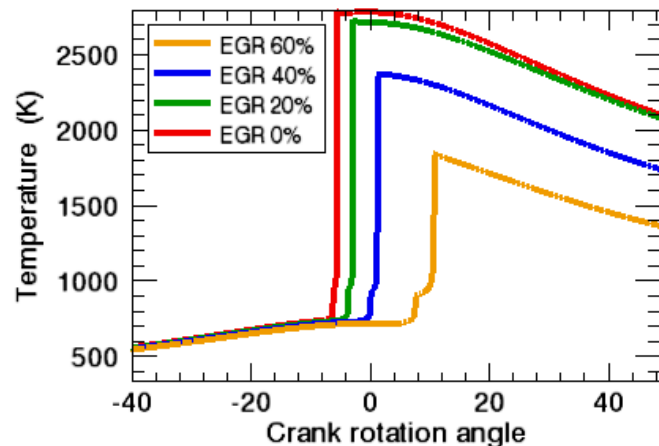

HCCI or PDC

# IC engine: SI, CI, HCCI

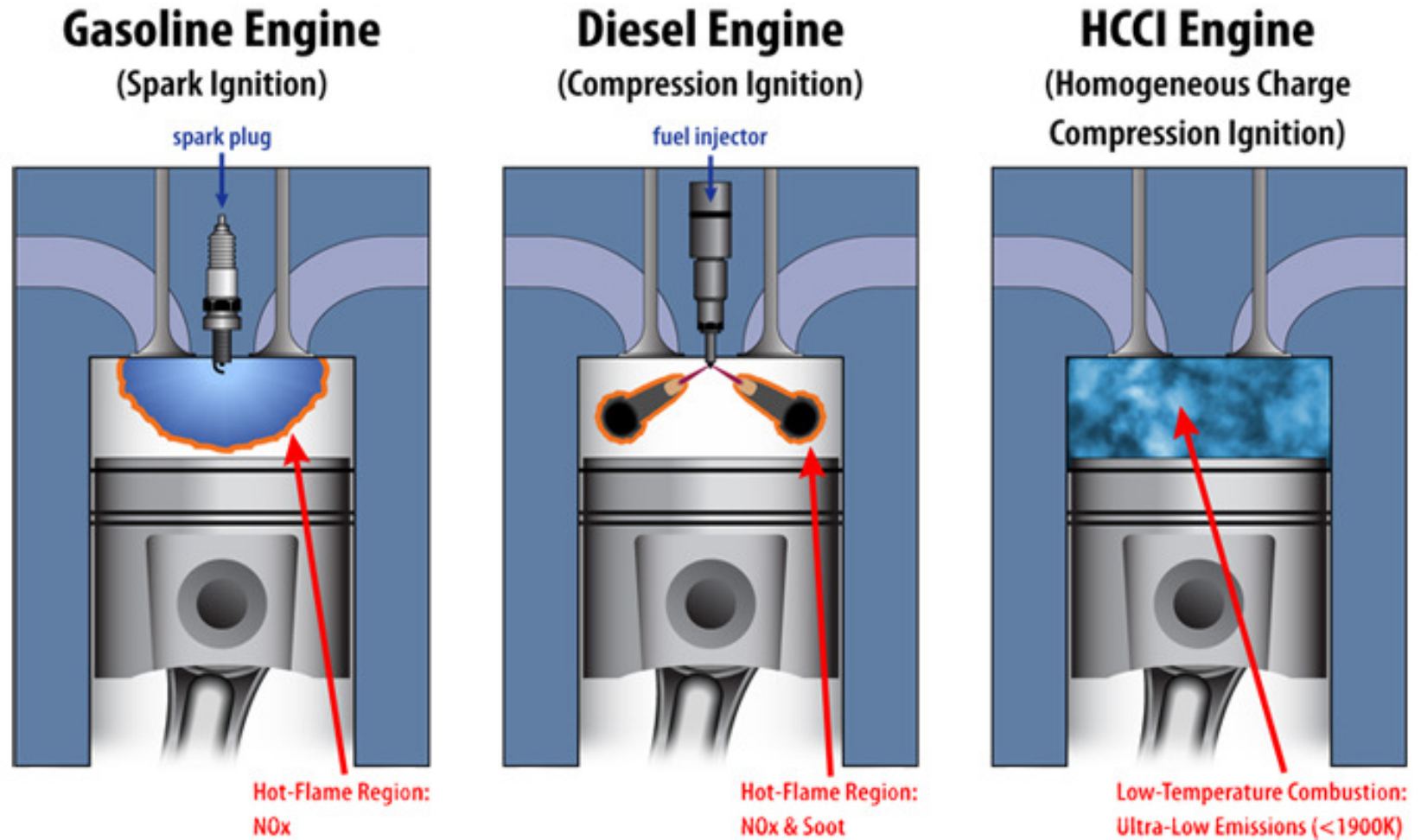

# Dual Fuel Combustion

- Natural gas and Air mixture is compressed
- Diesel is injected
- Diesel particles autoignite and acts as multiple spark plug
- Lean mixture may be burnt
- Cheaper fuels can also be burnt